

CAD FILE:

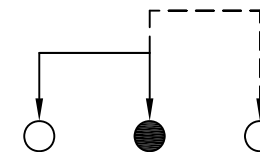

**SCHEMATIC (SHORTING)**

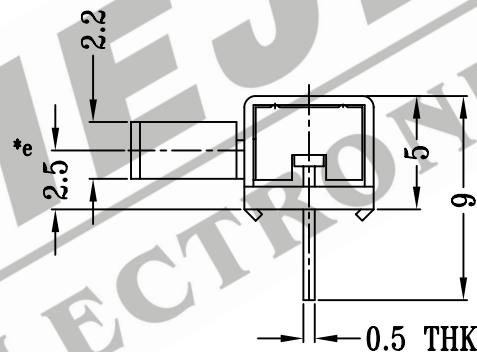
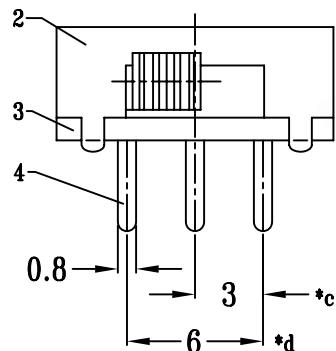
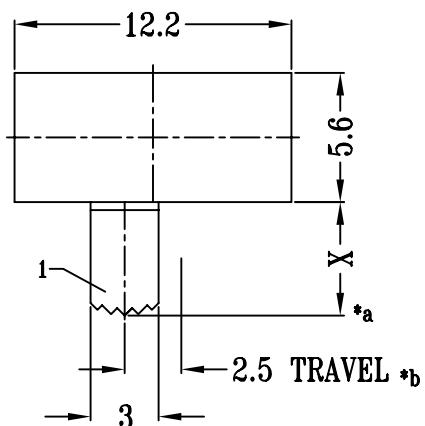
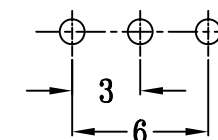

**P.C.B LAYOUT**

注:带"\*"表示关键尺寸(5个)

NO.	PART NAME	MATERIAL	Q'TY	FINISHING	TOLERANCE UNLESS SPECIFIED	SHENZHEN XIEJIA ELECTRONICS CO.,LTD.				
8										
7										
6	SPRING	STEEL WIRE	1	TEMPER	WITHIN: 1.5±0.1mm	ISSUE	DATE	DESCRIPTIONS		APPD.
5	CONTACT CLIP	BRASS STRIP	1	Ag PLATED	OVER : 1.5±0.2mm					
4	TERMINAL	BRASS STRIP	3	Ag PLATED OVER Ni PLATED	TITLE : HORIZONTAL SLIDE SWITCH		UNIT : MM	DRWG NO.: XJ-DR-SK12F04-00		
3	BASE	PHENOLIC RESIN	1	NATURAL	MODEL: SK-12F04		SCALE: 3 : 1	DWN.	ZHOUYU	2002-9-18
2	FRAME	STEEL STRIP	1	Ni PLATED				CHK'D	FANGYING	2002-9-18
1	KNOB	POM	1	BLACK				APPD.	KANGXINAN	2002-9-18
					ALL MATERIALS MUST BE COMPLIANT TO ROHS					